

Wood burning stoves



Why a wood burning stove?

Heating a house with wood is becoming increasingly popular in the UK. Open fires have always been popular, but the efficiency of burning logs in a grate is very low—only about 25% efficient. In contrast, modern wood burning stoves can have over 80% efficiency. Modern stoves can be even 'greener' when using a 'cleanburn or cleanheat' system in which the gases created when the wood is burnt are circulated back into the stove and burnt off. This increases the heat output and reduces emissions.

Wood is a carbon neutral fuel and although it releases carbon dioxide when it burns, the amount given off is the same as was stored by the tree as it grew.

Further environmental advantages of using wood are:

- ◇ Wood is a source of renewable energy as long as it comes from sustainable sources (where trees come from a managed woodland or where the wood for burning is a by-product of other activities such as forest residues, for example left over wood that has been harvesting for another reason, tree surgery waste or wood residues from wood processing plants)
- ◇ British woodlands are managed natural environments and benefit from active management
- ◇ Using local wood can benefit the rural economy

Wood burners can be used to provide heat for the room it stands in or, by heating water and pumping it through pipes it can provide heat to several rooms, and/or a domestic hot water system via a boiler.

This can even be extended to provide heat to several buildings from the same boiler, which is known as district heating.

This fact sheet focuses on wood stoves used for heating a home.

What are wood burning stoves?

A wood burning stove is a heating appliance that is capable of burning wood logs, a multi-fuel, or pellets (small pieces of compressed saw dust which are automatically fed into the fire).

Most people use logs, but to increase efficiency, they should be well season (dried under cover for at least a year) to reduce their moisture content.

The burner is normally made of a solid metal closed fire chamber and a grate and has adjustable air control. It must be connected to a chimney or flue and can either be floor mounted or set into a chimney breast.

Depending on the size of the stove installed and the layout of the home a single appliance can be used to heat one or more rooms. Some models can be used to supplement the hot water and some can also be used for cooking.



Cooking and heating



Wood burner in existing fire place

Things to consider

What is the availability of fuel in my area? Wood is widely available in the UK. However, it is important to remember that the environmental benefits of having a wood burner would be reduced if the fuel had to be transported over long distances. The National Energy Foundation maintains a database of wood fuel suppliers and you can search for a supplier in your area (see useful websites).

Do I have enough space to store a useful amount of wood in dry, well ventilated conditions? A covered space of at least three cubic metres relatively close to the house would be advisable (as you would be the one trudging in and out to get it!). If you are sourcing your own wood you would also need to consider that this would have to be kept in dry conditions for at least a year to 'season' before burning it. Only well seasoned wood should be burnt and should be from a sustainable source. You should avoid using any wood that may have been chemically treated as it could be hazardous to your health when burnt.



Am I allowed to burn wood?

To effectively control levels of smoke, many towns and cities now have smoke control areas especially in city centres. You are not allowed to burn fuel that emits smoke in a Smoke Control Area either in a stove or fireplace. Your local authority can tell you if you are in a Smoke Control Area.

There are certain clean-burning wood burning stoves which are exempt; this means that you can burn wood on them in smoke control areas. These have been tested and shown to produce low emissions when burning wood and may

be used in Smoke Control Areas. Appliances are exempted separately in the different countries of the UK and you can find a list of appliances exempted and which fuel you may use on the UK Smoke Control Areas webpage (see useful websites).

Is it easy to operate?

Modern wood burners are easy to operate. Provided it burns efficiently and dry logs are used even in daily use the stove should not need cleaning out more than every few weeks. In fact, a bed of ashes helps the wood to burn. And if the stove has self-cleaning 'airwash' glass a clear, attractive view of flickering flames is guaranteed. With very little regular maintenance you can keep your stove in tip top condition.

Do I want just heat or heat and hot water?

If you want a wood stove that can contribute to the hot water as well as provide heating you will need to install a stove with a back boiler. A wood boiler stove is an appliance that can burn wood to create hot water. Some look like traditional wood burner stoves whilst others look and work much more like a gas boiler.

There are various types of boiler for wood stoves available but they all do the same job: they transfer heat from the burning wood into water, which can then be piped where it is needed and used for heating or domestic hot water. You will want to seek professional advice to establish the size of boiler suitable for your home.

What size stove do I need?

You will need to buy the appropriate size stove for the room you want to heat, so you will need to note the cubic metres of the room as well as the size of the windows and doors. Heat output is measured in kilowatts (kW) and the stove size as well as type of chimney, flue



and wood burned, determine how much heat is radiated per hour.

If the stove is too big for the room, the room will become too hot on standard settings. It is important to burn the fuel at a fast rate and high temperature as slow burning of wood is not efficient and will lead to smoke and tar deposits in the chimney and flue. You can use tools such as the 'Stovesonline kilowatt calculator' to get an idea of the maximum heat output in kW needed for any room.

Where am I going to put it?

A stove needs a flue and this can be installed into an existing chimney. However, there are now ultra modern freestanding stoves on the market where the flue rises straight up through the ceiling. Where there is an existing chimney, it will need to be lined. Even if the chimney is already lined, unless the age of the lining can be accurately determined, it is likely that you will be advised to have a new liner. The cost of lining the chimney or installing a flue can be as much as the cost of the stove

Who is going to install it?

In England and Wales, there are only two routes to legal installation; you can either use a registered installer or apply directly to the local authority.

A registered installer can self-certify that the work they do complies with the relevant Building Regulations. A list of registered installers in your local area can be found from HETAS. This is the official body recognised by government to approve solid fuel domestic heating appliances, fuels and services. The installer will leave you with a Certificate of Compliance which is forwarded to HETAS who will in turn notify the local building control officer on your behalf.

Alternatively, you can apply directly to the local authority building control department for a building notice. Note that failure to notify the work through the registration scheme or directly to the local authority can lead to enforcement. It can also cause problems for future house sales if there is no official record of a compliant installation.

A competent installer will be able to advise you on the size of stove you need, ventilation requirements, assess the chimney to check that it is in good order or advise on installing a new flue.

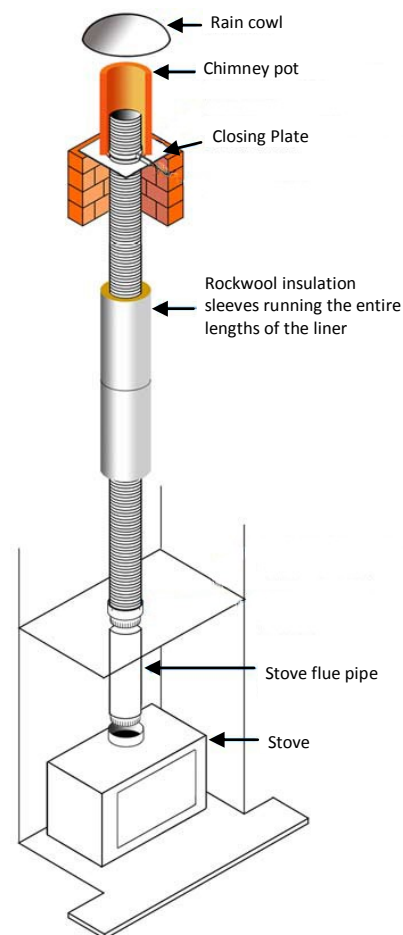

Useful websites

- www.nef.org.uk/logpile/index.htm
- smokecontrol.defra.gov.uk/
- www.stovesonline.co.uk
- www.biomassenergycentre.org.uk
- www.hetas.co.uk/

© 2010 National Energy Services Ltd

Disclaimer regarding general information:

This fact sheet is one of a series, made available by the membership schemes owned and operated by National Energy Services Ltd. They are only intended as general guides to provide background information, and whilst all reasonable steps have been taken to ensure their accuracy, neither National Energy Services Ltd., nor the membership schemes operated by it, can be held liable for any errors or omissions contained herein, nor any loss or damage howsoever arising from the use of this fact sheet, or variants of it.